

--

	INDIAN SCHOOL AL WADI AL KABIR	
Class: XII	Department: SCIENCE 2023 – 2024 SUBJECT: <u>ENGINEERING GRAPHICS</u>	Date of completion: 03.09.23
Worksheet No:3 With Answers	Topic: <u>BEARINGS</u>	Note: A4 FILE FORMAT
NAME OF THE STUDENT	CLASS: XII SECTION: C	ROLL NO.

QUESTIONS

1. Figure shows the assembly of an 'Open Bearing'. Disassemble the parts correctly and then draw to scale 1:1 its following views of the components. Keep the position of components same with respect to H.P and V.P. both;

(1) BODY

(a) Front view, left half in section.

(b) Top view, without section.

(2) BUSH

(a) Front view, left half in section.

(b) Side view, viewing from left.

(3) Print titles of both and the scale used. Draw the projection symbol. Give 6 important dimensions.

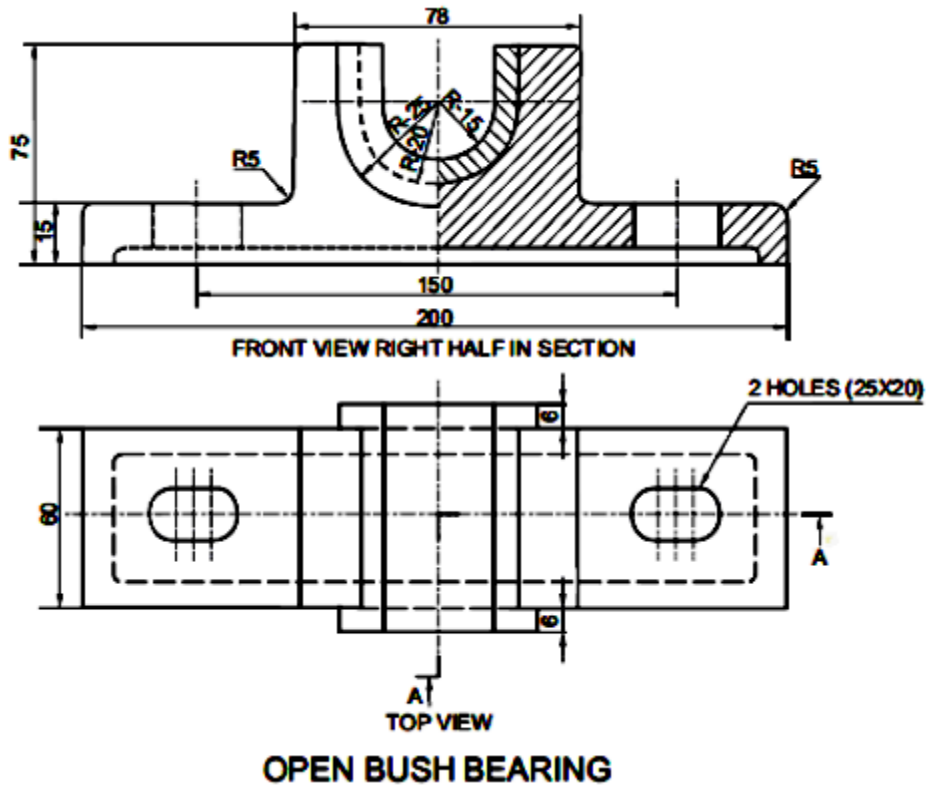

2. The Fig shows the assembly of Bushed Bearing. Dis-assemble the parts, and draw orthographic views of the following parts to scale 1:1, keeping same position:

(a) BODY

(i) Front View, right half in section.

(ii) Top View.

(b) BUSH

(i) Front View, left half in section.

(ii) Top View.

(c) Give 6 important dimensions, Title, Projection symbol and Scale.

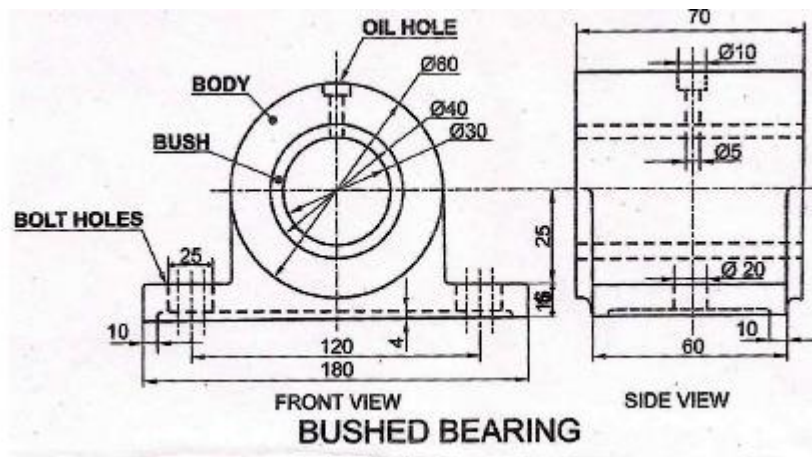

MULTIPLE CHOICE QUESTIONS

1. Which machine part prevents the rotation or sliding of the bush?

- a) Body of bearing
- b) Pulley
- c) Dowel pin
- d) Oil hole

2. A drawing which shows how parts are put together is known as:

- a) Perspective drawing
- b) Assembly drawing
- c) Isometric drawing
- d) Detail drawing

3.A machine element which supports and guides a rotating shaft is called....

- a) Bearing
- b) Pulley
- c) Cotter
- d) Coupling

4.The portion of the shaft lying within the bearing is called -----

- a) brass
- b) bush
- c)journal
- d) body

5.A machine part which is not sectioned is called -----

- a) bush
- b)snug
- c) rivet
- d) None of the above

6.Sectioned area is shown by -----

- a)colouring
- b)hatching lines
- c)dots
- d)All of these

7. Which bearing consists of a U shaped cast iron body?

- a) Bushed bearing
- b) Open bearing
- c) Pivot bearing
- d) Plummer block bearing

8. Bush is made of up of -----

- a) Cast iron
- b) Steel
- c) Gun metal
- d) Wood

9. Which bearing is useful for shafts rotating at low speed?

- a) Bushed bearing
- b) Open bearing
- c) Pivot bearing
- d) Plummer block bearing

10. Use of bearings helps to reduce -----

- a) Electricity
- b) Friction
- c) load
- d) dowel pin

ANSWERS

MULTIPLE CHOICE QUESTIONS

- 1.c) Dowel pin
- 2.b) Assembly drawing
- 3.a) Bearing
- 4.c) Journal
- 5.b) Snug
- 6.b) Hatching lines
7. b) Open bearing
8. c) Gun metal
9. b) Open bearing
10. b) Friction

SOLUTIONS FOR DRAWINGS

1.OPEN BEARING (Dis-assembly)

(1) BODY

(a) FRONT VIEW (Left Half in Section):

(i) Drawing left half with mounting hole and recess at bottom.

(ii) Drawing right half.

(iii) Hatching lines.

(b) TOP VIEW:

(i) Drawing boundary with four vertical lines.

- (ii) Hidden lines.
- (iii) Drawing both mounting holes.
- (iv) Drawing cutting plane.

(2) BUSH

(a) FRONT VIEW (Left Half in Section):

- (i) Drawing left half.
- (ii) Drawing right half.
- (iii) Hatching lines.

(b) LEFT SIDE VIEW:

- (i) Drawing complete view with hidden lines.

(3) Printing titles of both, scale used, drawing projection symbol, and six dimensions.

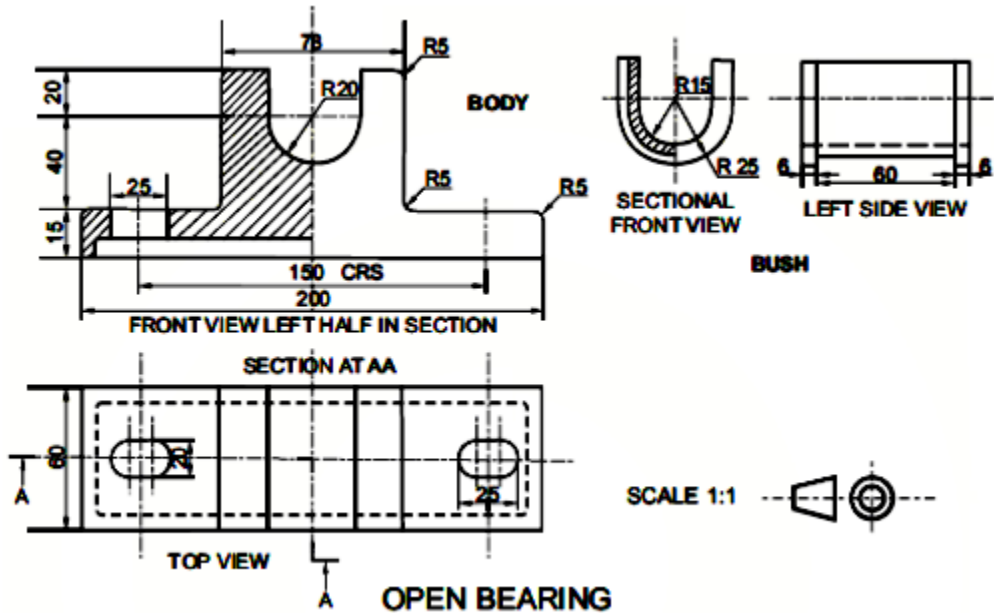

2. DIS-ASSEMBLY OF BUSHED BEARING

(a) BODY

(i) Front View. Drawing right half in section.

Drawing left half without section.

(ii) Top View with cutting plane.

(b) BUSH

(i) Front View, left half in section.

(ii) Top View with cutting plane.

(c) DETAILS: Printing title, scale used, drawing projection symbol and printing six dimensions

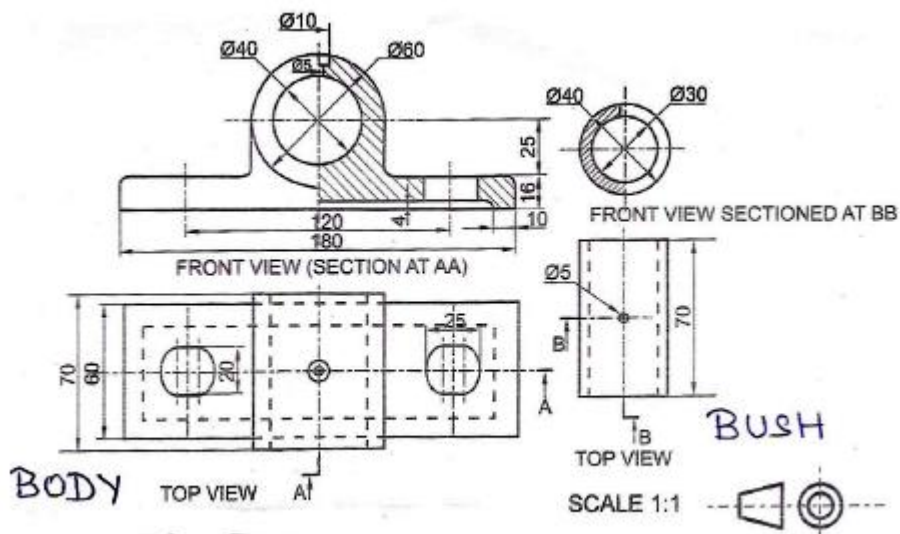

Prepared by:
Ms. Aiswarya Deepthi.P

Checked by:
HOD-Science & French

